

2796 Culver Ave., Dayton, Ohio 45429
513/294-1041

**GEARMOTORS
DC PERMANENT MAGNET
MILITARY QUALITY**

**MODEL DMR
BULLETIN 151A100/116**

ELECTRICAL SPECIFICATIONS

Voltage: 3, 6, 12, 27, 50 and 115 VDC are standard. Other voltages available. Reverse side of sheet shows complete DMR gearmotor data.

Speed: Motor input speeds up to 16,700 RPM can be used to drive this precision planetary geartrain, of ratios from 3.67 to 6564.

Connection Method: Double conductor shielded cables, #22 AWG per MIL-W-16878, type E.

Rotation: Counter clockwise when viewed from shaft end, when positive lead (red) is plus and negative lead (black) is minus.

Reversibility: Unit reverses rotation when voltage is reversed.

The Motor Technology Model DMR planetary gearmotor is designed and built for precision, durability and high torque-to-size performance. Common uses include military, aerospace and medical applications — where the needs for performance and dependability rank tops in priority. For pinions, RFI filters, brakes or any modifications you may need, consult with M.T.I. application engineers. See Bulletin 150A100 for additional motor information.

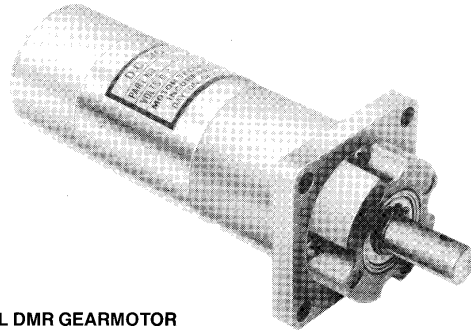

MODEL DMR GEARMOTOR

MECHANICAL SPECIFICATIONS

Rating: .025 hp with torques to 100 lb. in.

Gears: Precision cut, heat treated alloy steel.

Bearings: Output shaft supported by two ball bearings to support overhung loads. Needle bearings available for special side load conditions. All planet gears are mounted on anti-friction bearings.

Backlash: Less than 3°.

Shaft: Precision ground 8620 alloy steel per QQ-S-624, heat treated and case hardened.

Protection: Aluminum parts finished per MIL-C-5541A. Ring gear cadmium plated per QQ-P-416, type 2, class 2.

Lubrication: Motor bearings life lubricated per MIL-G-3278. Gearbox lubricated with grease per MIL-G-23827A. Special lubes are available.

Weight: 17 to 26 ounces, depending on ratios.

DIMENSIONS

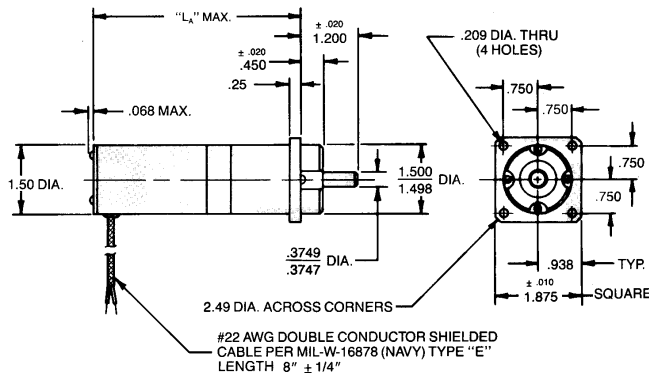

**MODEL DMR
BULLETIN 151A100/116**

**GEARMOTORS
DC PERMANENT MAGNET
MILITARY QUALITY**

2796 Culver Ave., Dayton, Ohio 45429
513/294-1041

BASIC GEARMOTOR DATA — STANDARD PART NUMBERS

SPEED REDUCTION RATIO	MAXIMUM ¹ CONT. DUTY TORQUE LB.IN.	TORQUE ² MULTIPLIER	LENGTH L _A DIMENSION	STANDARD DMR GEARMOTOR PART NUMBERS (Add armature dash number; see below.)
3.67	1.7	3.4	3.375	151A100-
5.80	2.7	5.4	3.375	151A101-
13.4	6.0	12.1	3.609	151A102-
21.3	9.6	19.2	3.609	151A103-
33.6	15.1	30.3	3.609	151A104-
49.3	21.1	42.3	4.093	151A105-
78	33.5	67	4.093	151A106-
123	51.5	105	4.093	151A107-
195	82.4	167	4.093	151A108-
286	100	233	4.328	151A109-
452	100	368	4.328	151A110-
715	100	583	4.328	151A111-
1132	100	928	4.328	151A112-
1658	100	1285	4.578	151A113-
2623	100	2030	4.578	151A114-
4149	100	3210	4.578	151A115-
6564	100	5080	4.578	151A116-

¹ This rating is for gearbox only. To determine output of any motor-gearbox combination, multiply motor torque by the torque multiplier for that ratio.

² Torque multiplier ratio is the gear ratio multiplied by its efficiency.

BASIC DMR ARMATURE DATA³

INPUT VOLTAGE DC	NO-LOAD SPEED RPM	RATED TORQUE OZ.IN.	STALL TORQUE OZ.IN.	NO-LOAD CURRENT AMPS MAX.	RATED TORQUE CURRENT AMPS	STALL CURRENT AMPS	ARMATURE DASH NUMBER
3	8,350	2.0	16.7	2.09	6.2	40.0	-1
6	13,360	2.0	26.7	1.66	5.0	50.4	-2
6	11,130	2.5	22.2	1.39	4.8	33.4	-3
6	8,900	3.5	17.8	1.11	4.8	21.2	-4
12	14,850	2.0	29.7	.928	2.6	28.0	-5
12	11,620	2.5	23.2	.726	2.5	17.4	-6
12	9,200	3.5	18.4	.575	2.5	11.0	-7
27	16,700	2.0	33.4	.464	1.3	15.7	-8
27	13,360	2.0	26.7	.371	1.0	10.0	-9
27	10,550	2.7	21.1	.293	1.0	6.30	-10
27	8,700	3.5	17.4	.241	1.0	4.12	-11
27	6,830	3.0	13.7	.190	0.7	2.55	-12
50	10,210	3.0	20.4	.153	.55	3.03	-13
50	8,000	3.0	16.0	.120	.42	1.89	-14
50	6,550	3.0	13.1	.099	.33	1.22	-15
115	11,960	2.5	23.9	.078	.24	1.77	-16
115	9,660	3.0	19.3	.063	.21	1.14	-17
115	7,270	3.0	14.5	.048	.17	.68	-18

³ For complete DMR motor data and tolerances see Bulletin 150A100.

HOW TO SELECT A UNIT

The complete part number must include a standard DMR gearmotor part number (above) plus an applicable DMR armature dash number from the basic motor data chart (left). Use the following trial and error technique to start:

1. Assume motor speed of 8,000 RPM and divide it by the required output speed to get approximate ratio.
2. From ratios charted above, select closest one.
3. Check maximum torque rating of that ratio with your actual requirement. Adjust ratio and motor speed up or down as needed.
4. Calculate output torque by multiplying motor torque by the "torque multiplier" of the ratio selected.
5. Select armature from voltage, load and speed required.

HOW TO ORDER: Order by standard part number (example: 151A107-11), making sure to include the armature dash number. Note any modifications as exceptions to the standard.