

2796 Culver Ave., Dayton, Ohio 45429
 PH: 513/294-1041 FAX: 294-8336

**GEARMOTORS
 DC PERMANENT MAGNET
 HIGH QUALITY INDUSTRIAL**

**MODEL HIR
 BULLETIN 276A200/208
 SUPERSEDES 276A100/112**

ELECTRICAL SPECIFICATIONS

Voltage: 12, 27, 50, 115 and 180 VDC are standard. Other voltages available. Reverse side of sheet shows complete HIR gearmotor data.

Speed: Motor input speeds up to 5480 RPM can be used to drive this precision planetary geartrain, of ratios from 3.81 to 170.

Connection Method: Two #18 AWG stranded leads, teflon insulated, 8" long are standard. Terminal type connections are available.

Rotation: Counter clockwise when viewed from shaft end, when positive lead (red) is plus and negative lead (black) is minus.

Reversibility: Unit reverses rotation when voltage is reversed.

The Motor Technology, Inc. Model HIR planetary gearmotor is designed and built to provide high efficiency, reliable performance and durability in a small package size. Common usages include robotic drives, industrial actuators, medical machines and instruments, automatic welding equipment, valve controls, etc. Where the need for dependability is paramount, the HIR gearmotor is an excellent choice. For pinions, splines, keyways, RFI/EMI filters, brakes or any modifications you may need, consult with M.T.I. application engineers. For higher ratios and greater torque output from the HIR gearmotor, see Bulletin 276A209/215. For additional HIR motor information see Bulletin 275A102.

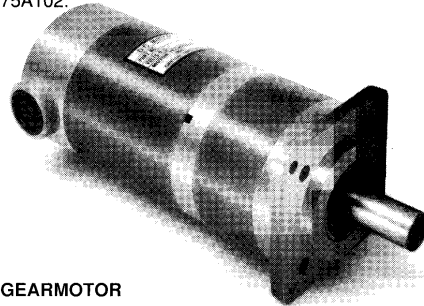

MODEL HIR GEARMOTOR

MECHANICAL SPECIFICATIONS

Rating: 0.20 hp with torques to 500 lb. in.

Gears: Precision manufactured and heat treated, high nickel alloy steel.

Bearings: Output shaft supported by double shielded ball bearings, but needle bearings are readily available. All planet gears are mounted on anti-friction bearings.

Backlash: Less than 3°.

Shaft: Precision ground 8620 alloy steel per QQ-S-624, heat treated and case hardened.

Protection: Aluminum parts finished with iridite chemical film. Ring gear tin-zinc plated, chromate finish per MIL-C-81562B, class 2, type 2.

Lubrication: Motor bearings life lubricated per MIL-G-3278. Gearbox lubricated with grease per MIL-G-23827A. Special lubricants are available.

Weight: 4.88 to 6.10 pounds, depending on ratios.

DIMENSIONS

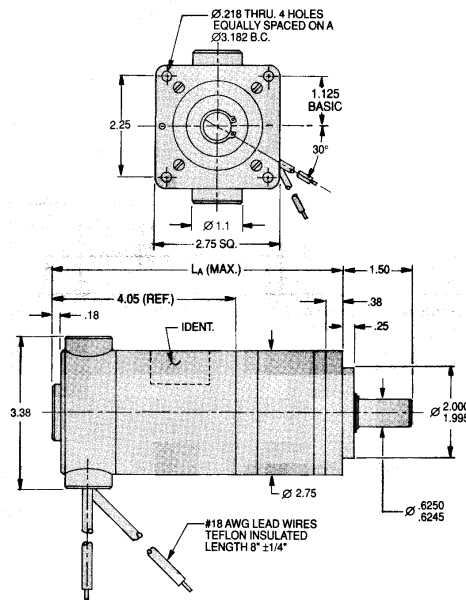

**MODEL HIR
 BULLETIN 276A200/208
 SUPERSEDES 276A100/112**

**GEARMOTORS
 DC PERMANENT MAGNET
 HIGH QUALITY INDUSTRIAL**

2796 Culver Ave., Dayton, Ohio 45429
 PH: 513/294-1041 FAX: 294-8336

BASIC GEARMOTOR DATA — STANDARD PART NUMBERS

SPEED REDUCTION RATIO	MAXIMUM ¹ CONT. DUTY TORQUE LB.IN.	TORQUE ² MULTIPLIER	LENGTH L _A DIMENSION	STANDARD HIR GEARMOTOR PART NUMBERS (Add armature dash number; see below.)
3.81	13.3	3.54	5.983	276A200-
5.54	19.3	5.15	5.983	276A201-
14.5	46.8	12.5	6.468	276A202-
21.1	68.2	18.2	6.468	276A203-
30.7	99.3	26.5	6.468	276A204-
55.3	166	44.5	6.953	276A205-
80.3	242	64.6	6.953	276A206-
117	353	94.1	6.953	276A207-
170	500	136	6.953	276A208-

¹ This rating is for gearbox only. To determine output of any motor-gearbox combination, multiply motor torque by the torque multiplier for that ratio.

² Torque multiplier ratio is the gear ratio multiplied by its efficiency.

BASIC HIR ARMATURE DATA¹

INPUT VOLTAGE DC	NO-LOAD SPEED RPM	RATED TORQUE OZ.IN.	STALL TORQUE OZ.IN.	NO-LOAD CURRENT AMPS MAX.	RATED TORQUE CURRENT AMPS	STALL CURRENT AMPS	ARMATURE DASH NUMBERS
12	5280	42	422	2.750	15.8	139	-1
12	3960	63	317	1.875	16.7	78	-2
12	3170	63	253	1.500	13.3	50	-3
27	5480	40	438	1.250	7.0	66	-4
27	4450	52	356	1.000	7.1	44	-5
27	3560	71	285	.750	7.4	28	-6
27	2850	50	228	.588	4.3	18	-7
50	4120	60	330	.488	4.0	20	-8
50	3300	60	264	.375	3.2	13	-9
50	2640	50	211	.288	2.1	8.3	-10
115	4740	48	379	.250	1.7	12	-11
115	3790	67	303	.188	1.8	7.5	-12
115	3030	50	243	.150	1.1	4.8	-13
180	3770	68	302	.125	1.1	4.7	-14
180	2970	50	238	.088	.67	2.9	-15

¹ For complete HIR motor data and tolerances see Bulletin 275A102.

HOW TO SELECT A UNIT

The complete part number must include a standard HIR gearmotor part number (above) plus an applicable HIR armature dash number from the basic motor data chart (left). Use the following trial and error technique to start:

1. Assume motor speed of 4,000 RPM and divide it by the required output speed to get approximate ratio.
2. From ratios charted above, select closest one.
3. Check maximum torque rating of that ratio with your actual requirement. Adjust ratio and motor speed up or down as needed.
4. Calculate output torque by multiplying motor torque by the "torque multiplier" of the ratio selected.
5. Select armature from voltage, load and speed required.

HOW TO ORDER: Order by standard part number (example: 276A205-5), making sure to include the armature dash number. Note any modifications as exceptions to the standard.