

**GEARMOTORS
DC PERMANENT MAGNET
HIGH QUALITY INDUSTRIAL**

2796 Culver Ave., Dayton, Ohio 45429
PH: 513/294-1041 FAX: 294-8336

**MODEL HIL
BULLETIN 276A229/235
SUPERSEDES 276A120/132**

**MODEL HIL
BULLETIN 276A229/235
SUPERSEDES 276A120/132**

**GEARMOTORS
DC PERMANENT MAGNET
HIGH QUALITY INDUSTRIAL**

2796 Culver Ave., Dayton, Ohio 45429
PH: 513/294-1041 FAX: 294-8336

ELECTRICAL SPECIFICATIONS

Voltage: 12, 27, 50, 115 and 180 VDC are standard. Other voltages available. Reverse side of sheet shows complete HIL gearmotor data.

Speed: Motor input speeds up to 5290 RPM can be used to drive this precision planetary geartrain, of ratios from 306 to 3582.

Connection Method: Two #18 AWG stranded leads, teflon insulated, 8" long are standard. Terminal type connections are available.

Rotation: Counter clockwise when viewed from shaft end, when positive lead (red) is plus and negative lead (black) is minus.

Reversibility: Unit reverses rotation when voltage is reversed.

For the engineer who likes the dimensions and performance capabilities of the Motor Technology HIR planetary gearmotor (Bulletin 276A209/215) but requires more torque output at higher speeds, the HIL offers a ready-made solution. Common usages include robotic drives, industrial actuators, medical machines and instruments, automatic welding equipment, valve controls, etc. Pinions, splines, keyways, RFI/EMI filters, brakes and other modifications are available. For higher output speeds and lower ratios, see Bulletin 276A220/228. Bulletin 275A107 contains complete information on the HIL motor.

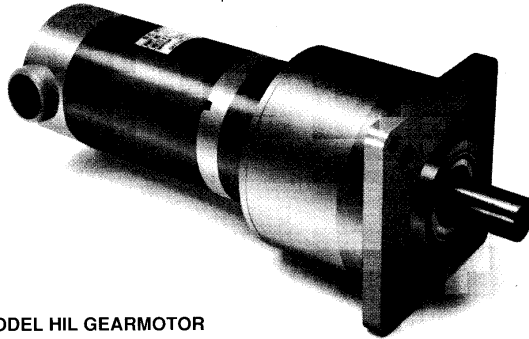

MODEL HIL GEARMOTOR

MECHANICAL SPECIFICATIONS

Rating: 0.33 hp with torques to 2400 lb. in.

Gears: Precision manufactured and heat treated, 8620 alloy steel.

Bearings: Output shaft supported by double shielded ball bearings. All planet gears are mounted on anti-friction bearings.

Backlash: Less than 3°.

Shaft: Precision ground 8620 alloy steel per QQ-S-624, heat treated and case hardened.

Protection: Aluminum parts finished with iridite chemical film. Ring gear tin-zinc plated, chromate finish per MIL-C-81562B, class 2, type 2.

Lubrication: Motor bearings life lubricated per MIL-G-3278. Gearbox lubricated with grease per MIL-G-23827A. Special lubricants are available.

Weight: 10.90 to 11.40 pounds, depending on ratios.

DIMENSIONS

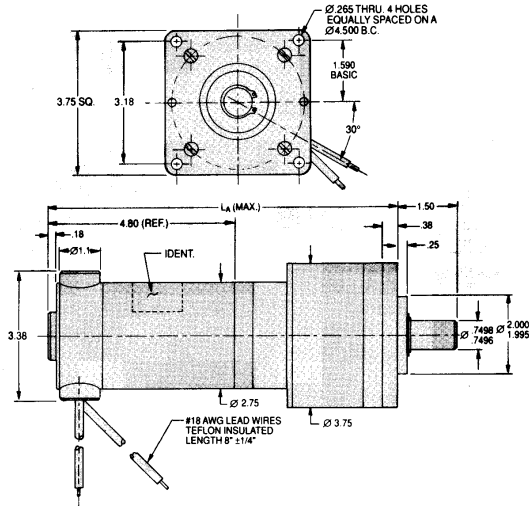

BASIC GEARMOTOR DATA — STANDARD PART NUMBERS

SPEED REDUCTION RATIO	MAXIMUM ¹ CONT. DUTY TORQUE LB.IN.	TORQUE ² MULTIPLIER	LENGTH L _A DIMENSION	STANDARD HIL GEARMOTOR PART NUMBERS (Add armature dash number; see below.)
306	1211	228	9.082	276A229-
445	1769	333	9.082	276A230-
647	2400	484	9.082	276A231-
940	2400	703	9.082	276A232-
1694	2400	1178	9.576	276A233-
2464	2400	1714	9.576	276A234-
3582	2400	2492	9.576	276A235-

¹This rating is for gearbox only. To determine output of any motor-gearbox combination, multiply motor torque by the torque multiplier for that ratio.

²Torque multiplier ratio is the gear ratio multiplied by its efficiency.

BASIC HIL ARMATURE DATA³

INPUT VOLTAGE DC	NO-LOAD SPEED RPM	RATED TORQUE OZ.IN.	STALL TORQUE OZ.IN.	NO-LOAD CURRENT AMPS MAX.	RATED TORQUE CURRENT AMPS	STALL CURRENT AMPS	ARMATURE DASH NUMBERS
12	3680	60	433	1.75	14.9	99	-1
12	2760	80	325	1.19	14.4	56	-2
27	4970	77	585	1.20	11.4	80	-3
27	3820	113	450	.83	12.5	48	-4
27	3100	91	365	.63	8.2	31	-5
50	4600	86	541	.58	6.3	37	-6
50	3680	100	433	.43	5.8	24	-7
50	2880	80	338	.30	3.6	15	-8
115	5290	71	622	.31	2.7	21	-9
115	4230	98	498	.23	2.8	14	-10
115	3310	98	389	.16	2.2	8.3	-11
180	4140	100	487	.14	1.8	8.4	-12
180	3310	97	390	.10	1.4	5.4	-13
180	2830	78	309	.08	.89	3.4	-14
180	2070	60	244	.05	.55	2.1	-15

³For complete HIL motor data and tolerances see Bulletin 275A107.

HOW TO SELECT A UNIT

The complete part number must include a standard HIL gearmotor part number (above) plus an applicable HIL armature dash number from the basic motor data chart (left). Use the following trial and error technique to start:

1. Assume motor speed of 4,000 RPM and divide it by the required output speed to get approximate ratio.
2. From ratios charted above, select closest one.
3. Check maximum torque rating of that ratio with your actual requirement. Adjust ratio and motor speed up or down as needed.
4. Calculate output torque by multiplying motor torque by the "torque multiplier" of the ratio selected.
5. Select armature from voltage, load and speed required.

HOW TO ORDER: Order by standard part number (example: 276A231-4), making sure to include the armature dash number. Note any modifications as exceptions to the standard.